

YT-300



YT-305



YT-310



YT-315



YT-320



YT-325



Contents

1	Introduction	3
1.1	General Information for the users	3
1.2	Manufacturer Warranty	3
2	Product Description	4
2.1	General	4
2.2	Main Features and Functions	4
2.3	Label Description	5
2.4	Product Code	6
2.5	Product Specification	6
2.6	Certifications of External products	7
2.7	Operation Logic	7
2.8	Parts and Assembly	8
2.8.1	YT-300 / 305	8
2.8.2	YT-310 / 315	9
2.8.3	YT-320 / 325	10
2.9	Product Dimension	10
2.9.1	YT-300 / 305	10
2.9.2	YT-310 / 315	11
2.9.3	YT-320 / 325	11
2.10	Flow Characteristics	12
2.10.1	YT-300, 305	12
2.10.2	YT-310, 315	12
2.10.3	YT-320, 325	13
3	Installation	14
3.1	Safety	14
3.2	Installation	15
3.3	Installation Example	16
3.3.1	Double acting linear cylinder actuator	16
3.3.2	Single acting rotary cylinder actuator	16
4	Maintenance	17
4.1	Replacement of Parts (Repair kit)	17
4.2	Trouble-Shooting	17

1 Introduction

1.1 General Information for the users

Thank you for purchasing Rotork YTC Limited products. Each product has been fully inspected after its production to offer you the highest quality and reliable performance. Please read the product manual carefully prior to installing and commissioning the product.

- Installation, commissioning, and maintenance of the product may only be performed by trained specialist personnel who have been authorized by the plant operator accordingly.
- The manual should be provided to the end-user.
- The manual can be altered or revised without any prior notice. Any changes in product's specification, design, and/or any components may not be printed immediately but until the following revision of the manual.
- The manual should not be duplicated or reproduced for any purpose without prior approval from Rotork YTC Limited, Gimpo-si, South Korea.
- In case of any other problems that are not stated in this manual, please make immediate contact to Rotork YTC Limited.

1.2 Manufacturer Warranty

- For the safety, it is important to follow the instructions in the manual. Manufacturer will not be responsible for any damages caused by user's negligence.
- Any modifications or repairs to the product may only be performed if expressed in this manual. Injuries and physical damages caused by customer's modifying or repairing the product without a prior consultation with Rotork YTC Limited will not be compensated. If any alterations or modifications are necessary, please contact Rotork YTC Limited directly.
- Standard type with NBR rubber (ambient temperature range option 1) is subject to damage by ozone. If you suspect that ozone may be present at the site or if supplied air is likely to contain ozone, select a high temperature version (ambient temperature range option 2) or a low temperature version (ambient temperature range option 3) with SILICONE rubber.
- The warranty period of the product is (18) months from the date of shipment unless stated otherwise. Date of shipment can be checked by providing the LOT NO. or SERIAL NO. to us.
- Manufacturer warranty will not cover products that have been subjected to abuse, accidents, alterations, modifications, tampering, negligence, misuse, faulty installation, lack of reasonable care, repair or service in any way that is not contemplated in the documentation for the product, or if the model or serial number has been altered, tampered with, defaced or removed; damages that occurs in shipment, due to act of God, failure due to power surge, or cosmetic damage. Improper or incorrectly performed maintenance will void this limited warranty.
- For detailed warranty information, please contact the corresponding local Rotork YTC Limited office or main office in South Korea.

2 Product Description

2.1 General

Volume booster relay, YT-300 / 305 / 310 / 315 / 320 / 325, is used in pneumatic control valve which receives the output pressure signal from positioner and supply air pressure to actuator to reduce opening and closing time of the valve.

2.2 Main Features and Functions

- Provides pneumatic pressure with stable 1:1 pressure ratio, excellent speed and accuracy.
- By-pass control enhances safety of the control valve operation.
- Sensitive response to small input changes of the positioner to deliver accurate and fast output to the actuator.
- SIL2 certified.(For more information, see SIL Safety Instruction on homepage)

2.3 Label Description

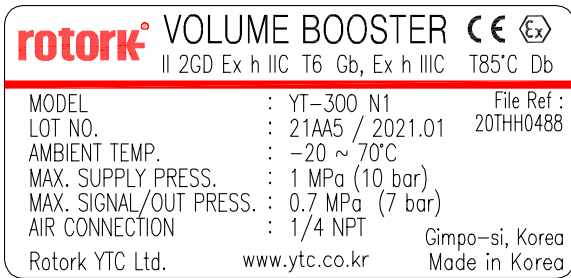

Fig. L-1: YT-300

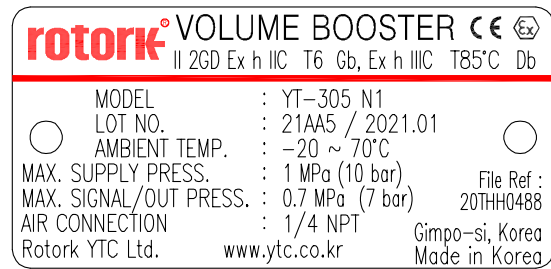

Fig. L-2: YT-305



Fig. L-3: YT-310 / 315



Fig. L-4: YT-320

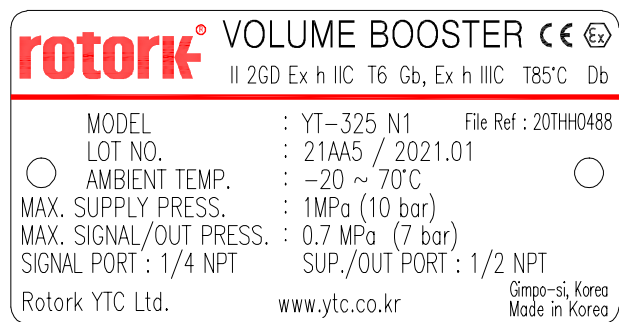

Fig. L-5: YT-325

- MODEL : Indicates the model number and additional symbols.
- LOT NO. : Indicates unique lot number.
- YEAR.MONTH : Indicates manufactured year and month.
- AMBIENT TEMP. : Indicates the allowable ambient temperature.
- MAX. SUPPLY PRESS. : Indicates the max. supply pressure.
- MAX. SIGNAL/OUT PRESS. : Indicates the max. signal / output pressure.
- SIGNAL/SUP./OUT PORT : Indicates connection thread type of signal/supply/outputport.

※ Precautions



Be careful not to apply volatile solvent (hardener of instant adhesive, acetone, WD-40, etc.) to the sticker nameplate. Printed contents may be erased.

2.4 Product Code

YT-300 / 305 / 310 / 315 / 320 / 325 1 2

1 Air Connection Type	P : Rc : only YT300 / 320 N : NPT
2 Ambient Temp.	1 : -20 ~ 70°C (-4 ~ 158°F) 2 : -20 ~ 120°C (-4 ~ 248°F) 3 : -40 ~ 70°C (-40 ~ 158°F) 4 : -60 ~ 70°C (-76 ~ 158°F)

2.5 Product Specification

Model		YT-300 YT-305	YT-320 YT-325	YT-310 YT-315		
Max. Supply Pressure		1 MPa (10 bar)				
Max. Signal / Output Pressure		0.7 MPa (7 bar)				
Signal / Output Pressure Ratio		1 : 1				
Flow Capacity (Cv)	Exhaust	1.32	2.08	5.24		
	Output	1.19	2.72	4.91		
Supply / Output Connection	YT-3x0	Rc 1/4 or 1/4 NPT	Rc 1/2 or 1/2 NPT	3/4 NPT		
	YT-3x5	1/4 NPT	1/2 NPT			
Signal Connection	YT-3x0	Rc 1/4 or 1/4 NPT		1/4 NPT		
	YT-3x5	1/4 NPT				
Linearity		± 1 % F.S.				
Ambient Temperature		Standard Temp. : -20 ~ 70°C (-4 ~ 158°F) High Temp. : -20 ~ 120°C (-4 ~ 248°F) Low Temp. : -40 ~ 70°C (-40 ~ 158°F) Arctic Temp. : -60 ~ 70°C (-76 ~ 158°F)				
Housing Material	YT-300, YT-320, YT-310	Aluminum				
	YT-305, YT-325, YT-315	Stainless Steel 316				
Weight	YT-300	YT-320	YT-310	0.51kg(1.1 lb)	0.77kg(1.7 lb)	1.9kg(4.2 lb)
	YT-305	YT-325	YT-315	1.4kg(3 lb)	1.9kg(4.2 lb)	4.6kg(10.1 lb)



Tested under ambient temperature of 20°C, absolute pressure of 760mmHg, and humidity of 65%.

Please contact Rotork YTC Limited for detailed testing specification.

2.6 Certifications of External products

※ All certifications below are posted on Rotork YTC Limited homepage(www.ytc.co.kr).

➤ **SIL2 {in a redundant architecture(HFT=1) up to SIL 3}**

Certification No. : 968/V 356.06/19

2.7 Operation Logic

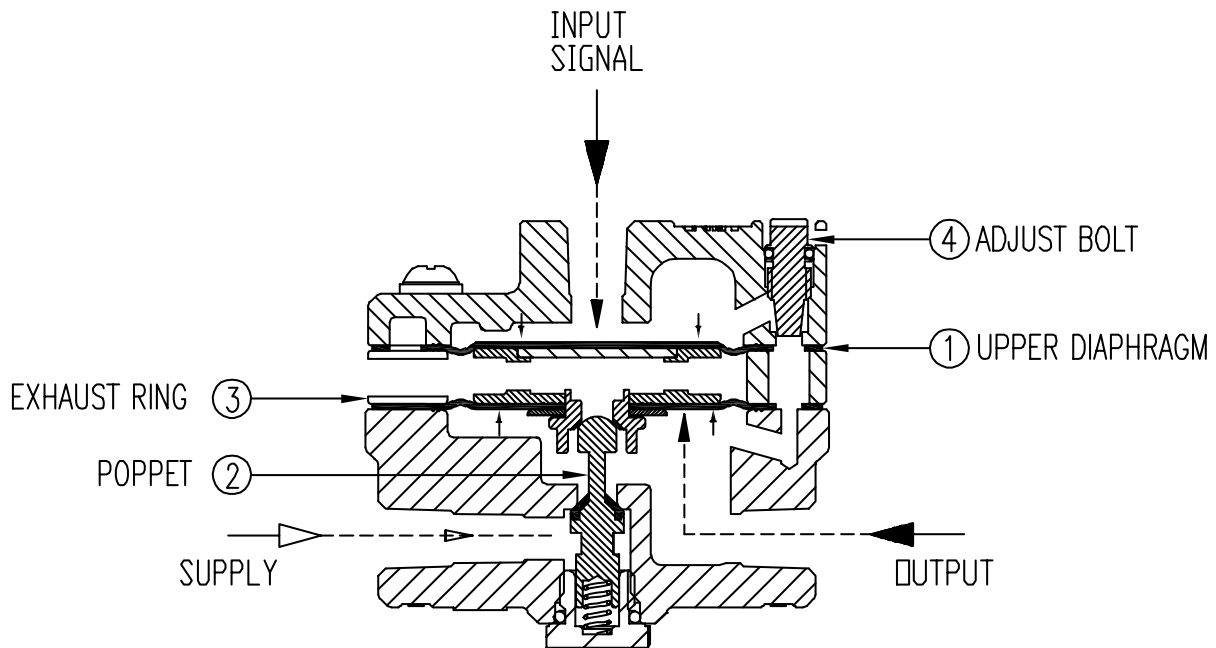

Fig. 2-1: Operation Logic

When the supply pressure from the regulator is supplied to the supply port (SUPPLY) and the signal pressure is input to the signal port (INPUT SIGNAL), ①the upper diaphragm is actuated and the assembled diaphragm assembly moves down and feed pressure is supplied to the actuator through the output port by pressing ②the poppet. Output pressure (OUTPUT) goes up and equalize with the signal pressure and the ②Poppet moves up and keep signal pressure and output pressure constant at 1:1 ratio. If the output pressure is higher than the signal pressure, the diaphragm assembly rises and discharges the output pressure to the exhaust port on ③the exhaust ring. The response sensitivity of the output pressure according to the signal pressure can be adjusted by ④the adjust bolt and it can be used to improve the stability of closed loop system including volume booster relay.

2.8 Parts and Assembly

2.8.1 YT-300 / 305

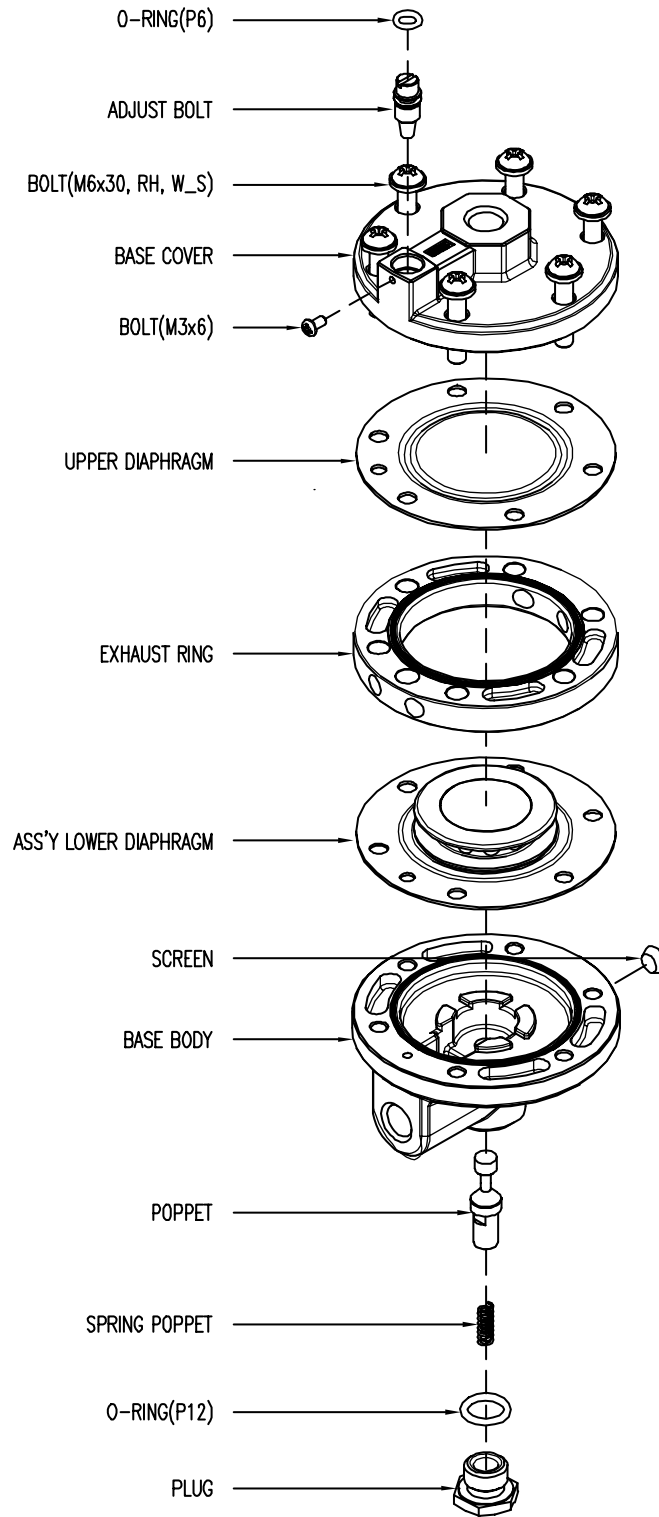

Fig. 2-2: YT-300 / 305 Parts and Assembly

2.8.2 YT-310 / 315

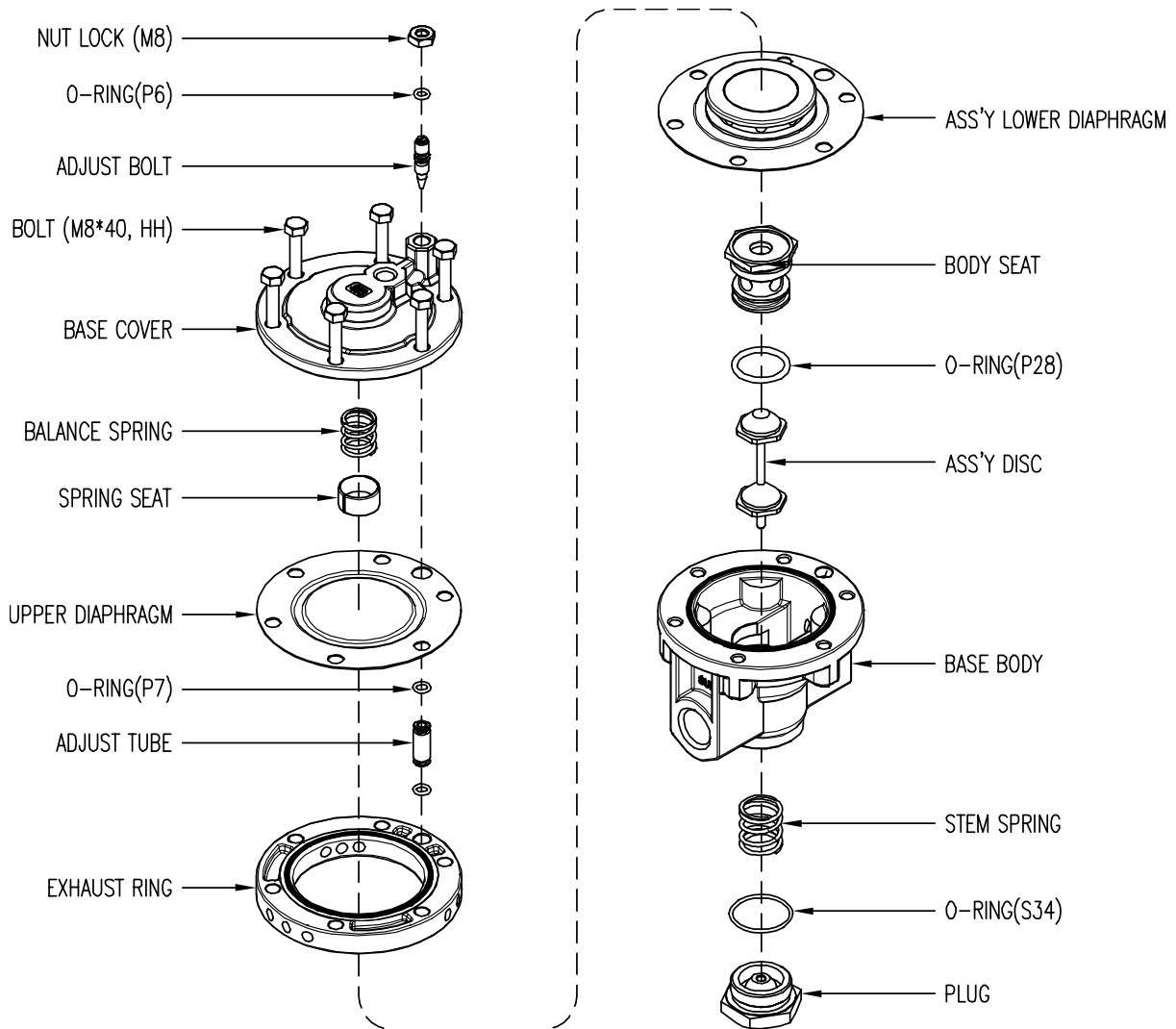

Fig. 2-3: YT-310 / 315 Parts and Assembly

2.8.3 YT-320 / 325

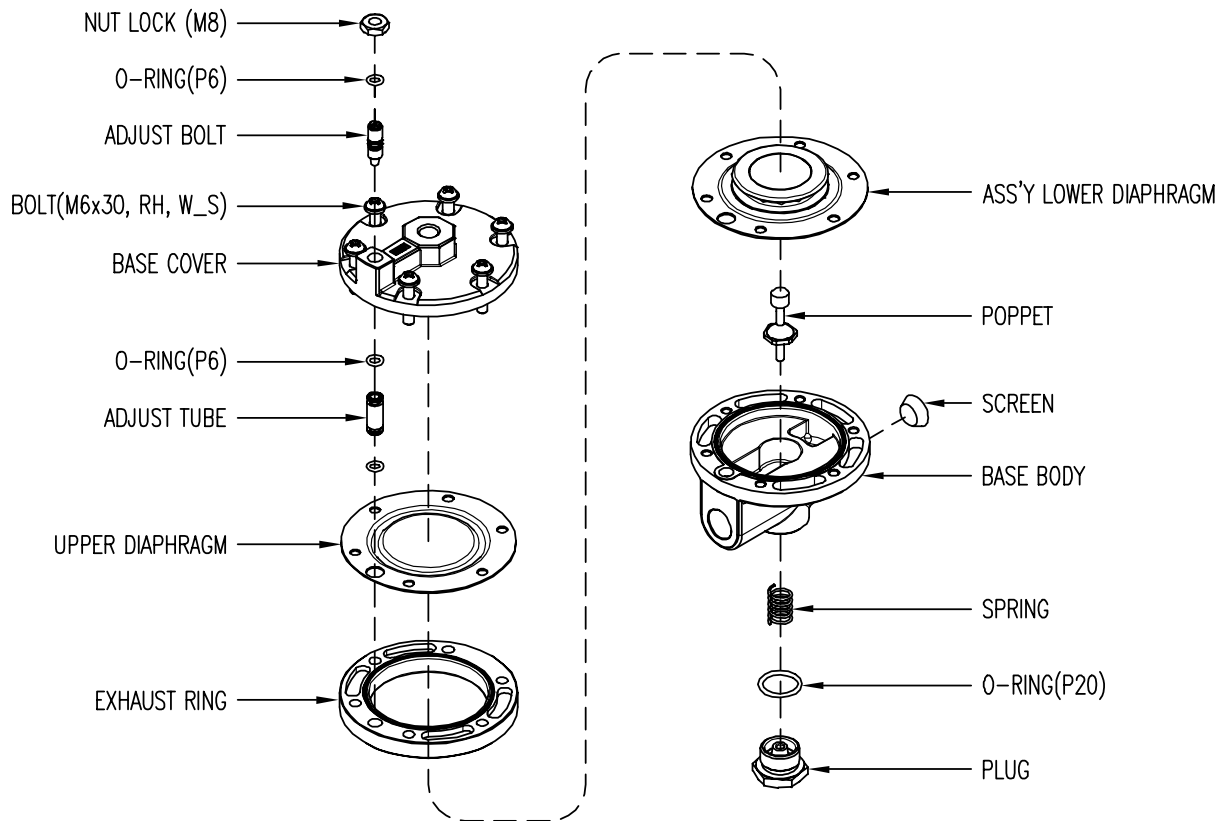

Fig. 2-4: YT-320 / 325 Parts and Assembly

2.9 Product Dimension

2.9.1 YT-300 / 305

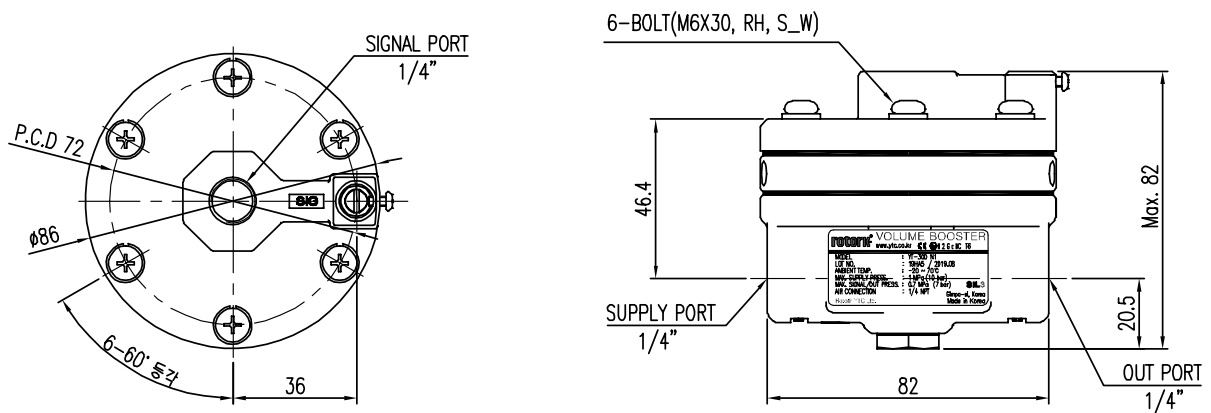

Fig. 2-5: YT-300 / 305 dimension

2.9.2 YT-310 / 315

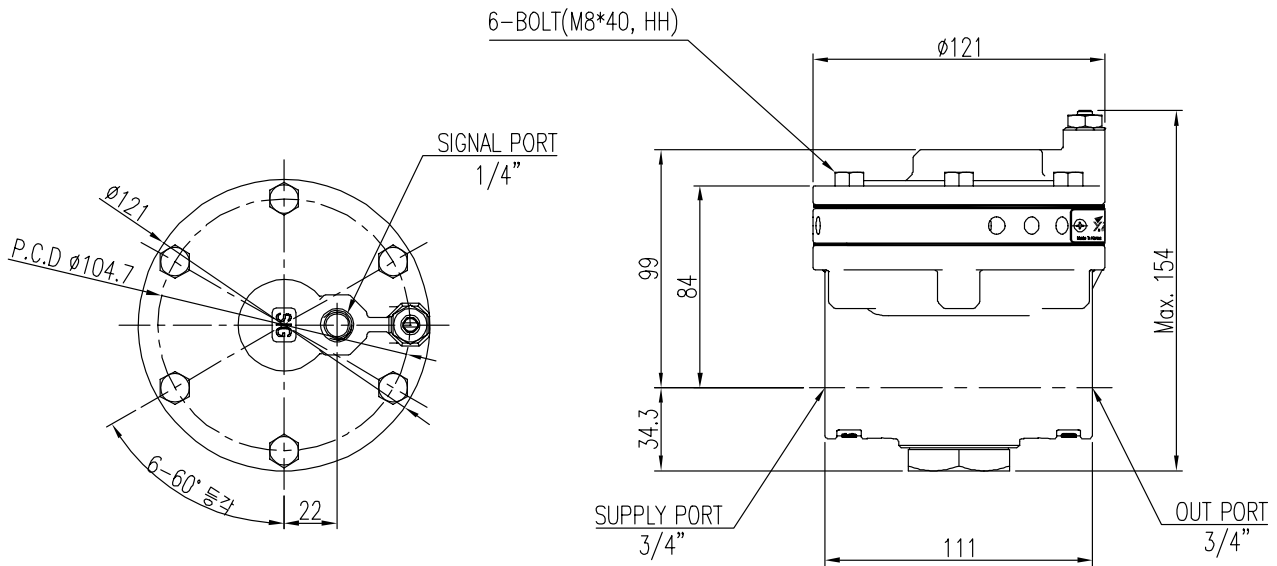

Fig. 2-6: YT-310 / 315 dimension

2.9.3 YT-320 / 325

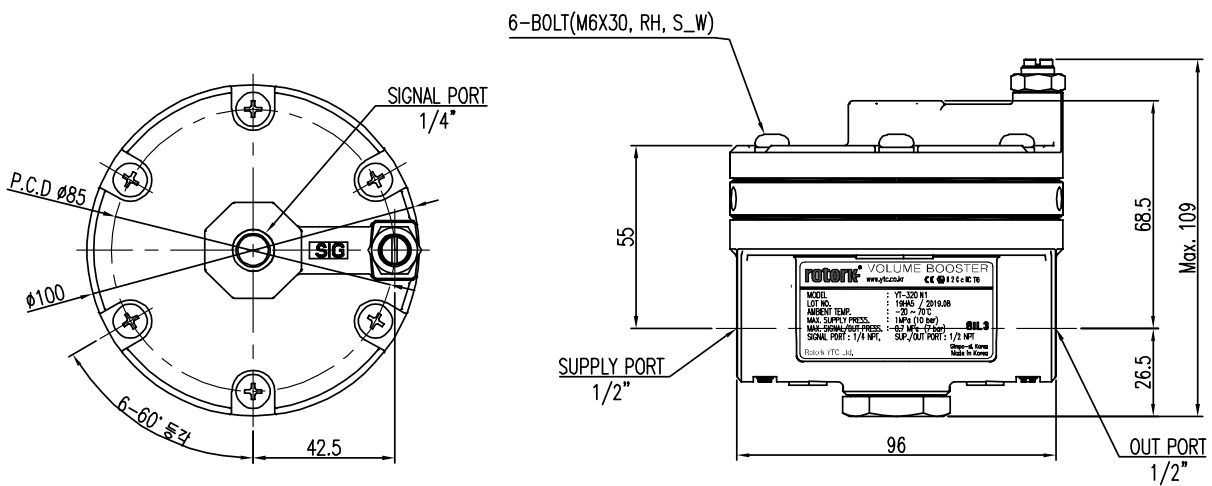

Fig. 2-7: YT-320 / 325 dimension

2.10 Flow Characteristics

2.10.1 YT-300, 305

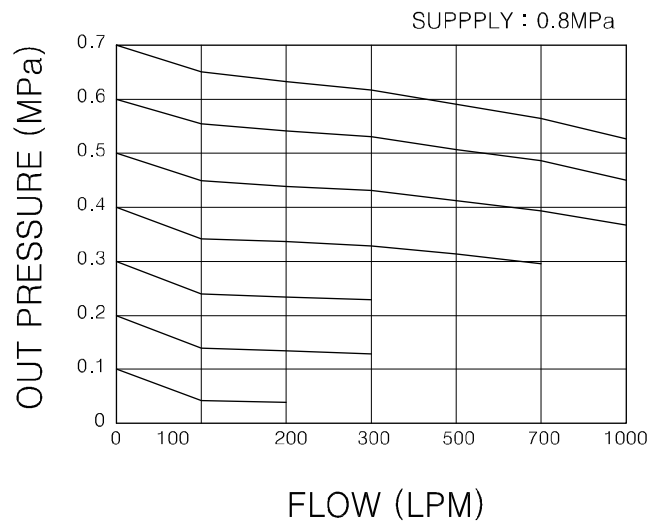

Fig. 2-8: YT-300 / 305

2.10.2 YT-310, 315

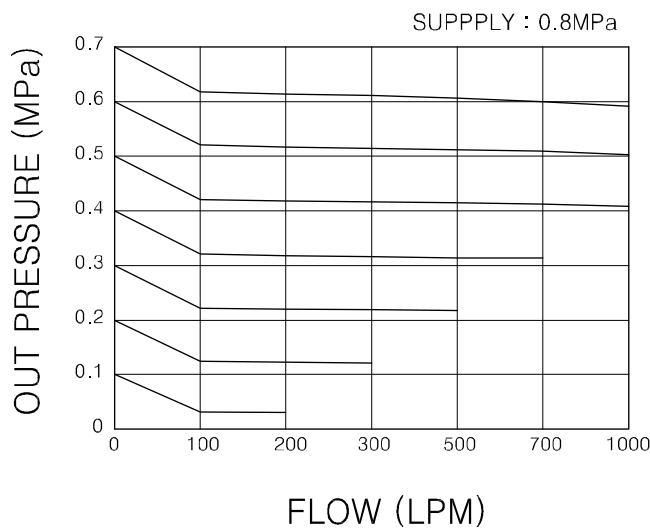

Fig. 2-9: YT-310 / 315

2.10.3 YT-320, 325

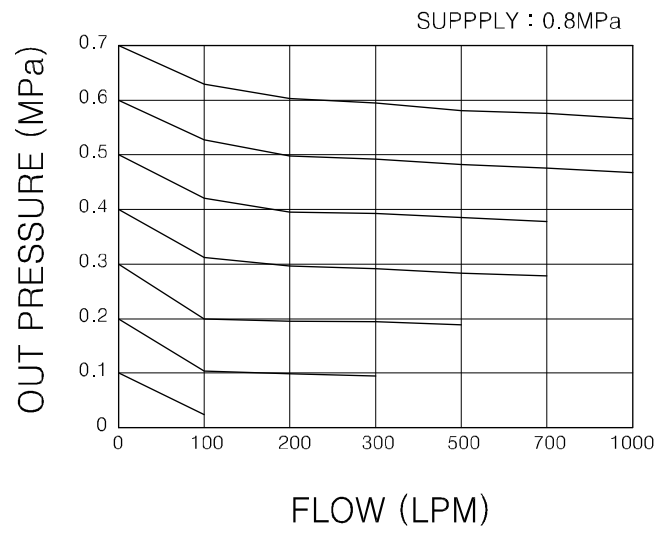

Fig. 2-10: YT-320 / 325

3 Installation

3.1 Safety

When installing a unit, please ensure to read and follow safety instructions.



- Be sure to have protective equipment and comply with safety regulations.
- Exceeding the specification may cause leakage, damage of parts or injury due to explosion of compressed gas. To avoid this damage, all pressure lines entering the volume booster must be disconnected and bypassed.
- Periodically turn off the volume booster for maintenance.
- Supply pressure should be clean air or non-corrosive gas and must be filtered.
- Discharge to the atmosphere is done through the exhaust port next to the volume booster.
- Care must be taken to ensure that foreign objects and obstructions do not clog the exhaust port. Also, install the unit in a well-ventilated area so that the exhaust gas is not in an enclosed space.
- It is recommended to install a large capacity pneumatic regulator that can guarantee the output capacity of the volume booster relay.
- Please make sure to install the product with signal port upward/downward. If not, inner parts can be easily worn or damaged if installed sideways.

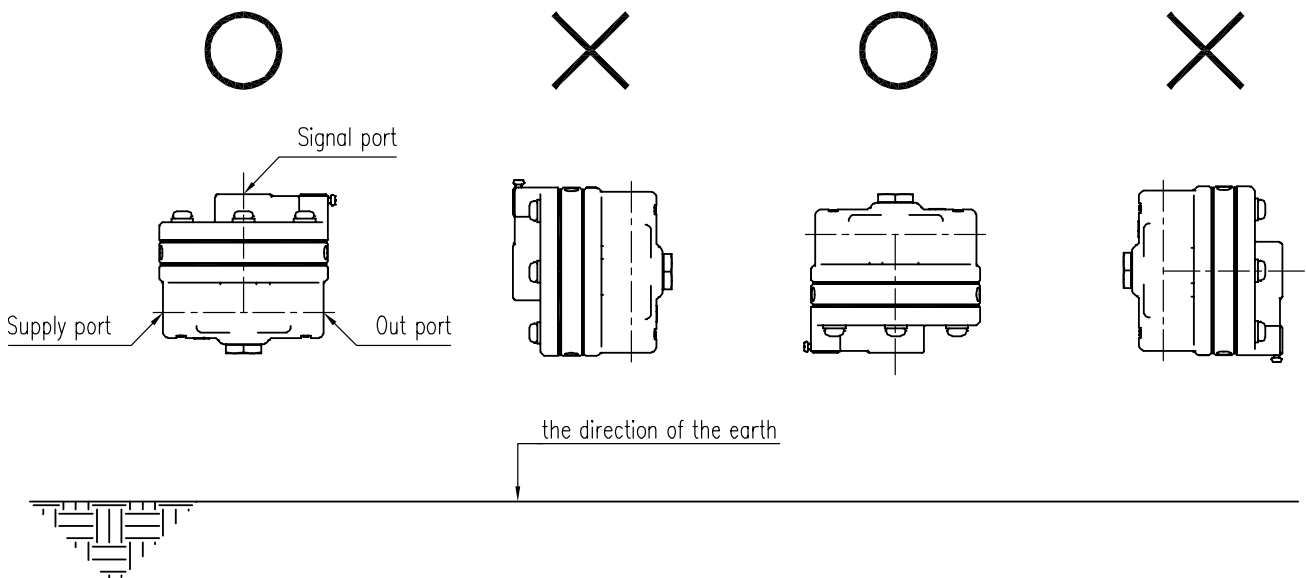

Fig. 3-1: The correct direction of the product installation

3.2 Installation

- The volume booster is located between the actuator, positioner and supply pipe and can be installed using only pneumatic piping without separate brackets as shown in the left figure. Before connecting the piping, be sure to blow out all piping so that no impurities can enter the volume booster relay and ensure that it is the right size to meet the required capacity.
- If a bracket is necessary due to the installation conditions of the site, you can check the dimension indicated on the drawing on the previous page and customize the bracket. There are several ways to use the bracket. For example, you can install it as shown in the right figure.

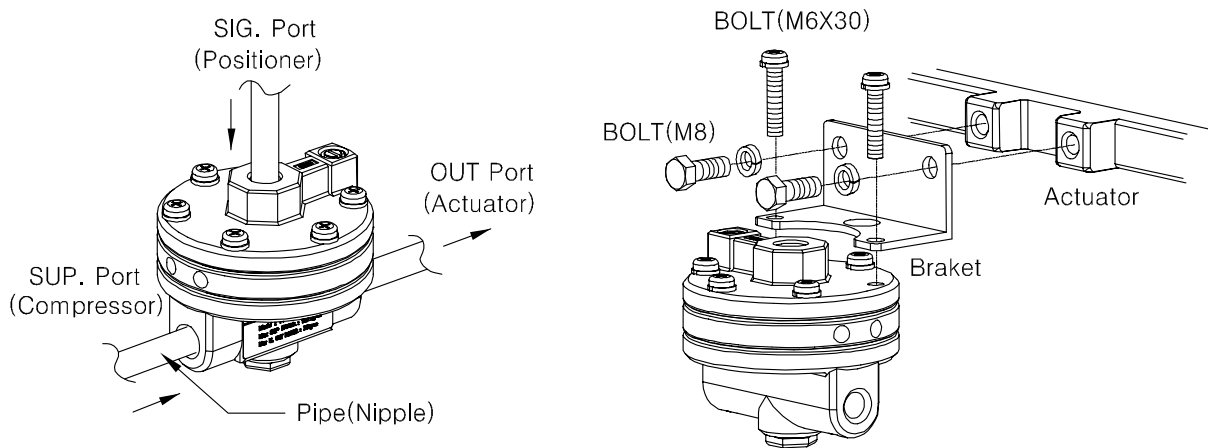

Fig. 3-2: How to install volume booster

3.3 Installation Example

3.3.1 Double acting linear cylinder actuator

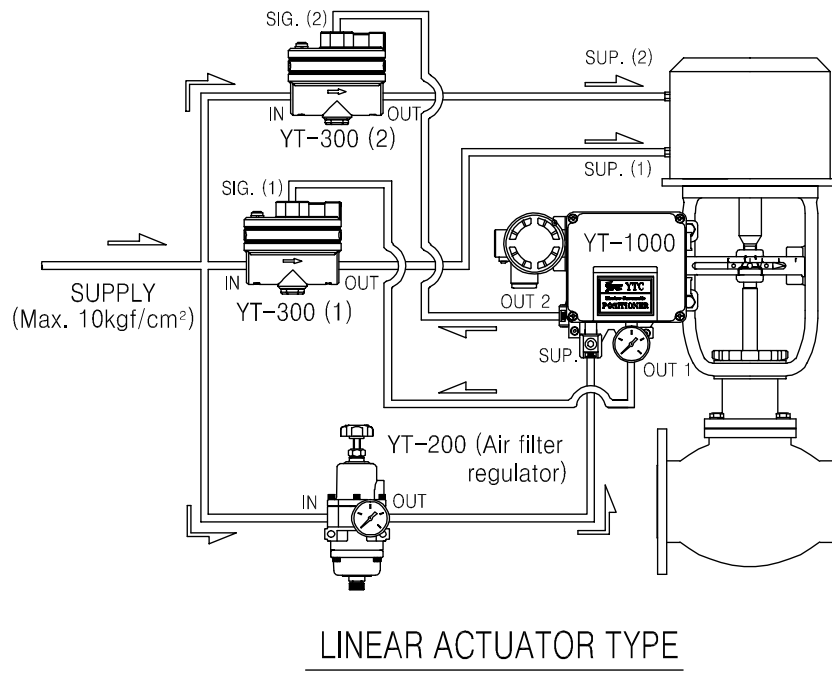

Fig. 3-3: Double example

3.3.2 Single acting rotary cylinder actuator

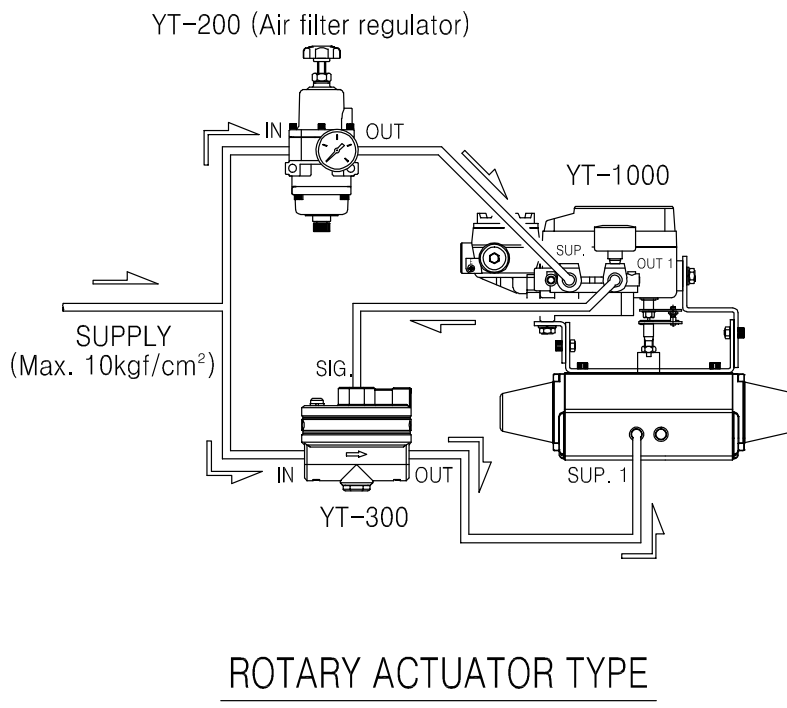

Fig. 3-4: Single example

4 Maintenance

4.1 Replacement of Parts (Repair kit)

The volume booster requires regular maintenance. In particular, periodic inspection is required as the diaphragm is not permanent even when used in the operating ambient temperature range. Even if there is no problem in the operation of the volume booster, disassemble it once every 2-3 years to check the condition of the diaphragm and replace it if necessary. Please refer to below repair part list. It is suggested to replace all two parts at the same time to guarantee the life cycle of the product.

- Ass'y- lower diaphragm: 1 each
- Upper diaphragm: 1 each

4.2 Trouble-Shooting

- 1) **When there is no operation of the valve with signal given to the positioner**
 - Please check if supply pressure is stable from regulator to positioner and/or to volume booster.
 - Please check if air pressure is being output from positioner's output port.
 - Please check if supply and/or output ports of volume booster are clogged.
- 2) **Unstable valve operation when signal has been sent to a positioner.**
 - Please reduce valve packing and/or valve friction level.
 - Make the actuator sizing larger.
- 3) **Hunting occurs when signal has been sent to a positioner.**
 - Please reduce valve packing and/or valve friction level.
 - Make the actuator sizing larger.
 - Please turn adjust screw counter-clockwise to reduce sensitivity.
- 4) **Slow valve operation after installing a volume booster.**
 - Please check if regulator pressure is too low.
 - Please check if supply piping to the actuator has been blocked or clogged.
 - Please check if there is any leakage in signal line.
 - Please turn adjust screw clockwise to enhance sensitivity.

Manufacturer: Rotork YTC Limited

Address: 81, Hwanggeum-ro, 89 Beon-gil, Yangchon-eup, Gimpo-si, Gyeonggi-do, South Korea

Postal code: 10048

Tel: +82-31-986-8545

Fax: +82-70-4170-4927

Email: ytic.sales@rotork.com

Homepage : <http://www.ytc.co.kr>

Issued : 2021-01-19

Copyright © Rotork YTC Limited. All Rights Reserved.